

# Submersible Single-phase Portable Drainage Pumps



## **A powerful high volume type now added to best-selling HS-series pumps**

The HS3.75SL & HSZ3.75SL model pumps are submersible single-phase portable drainage pumps that come with high volume drainage capability. These pumps are a low head, high volume drainage type launched under Tsurumi's proudly best-selling HS-series. With high volume drainage performance, they are suited to specifically meet the needs of the rental market, as well as the civil engineering and the construction market.

As with the existing HS-series units, these operator-friendly submersible pumps are compact and lightweight, i.e. highly portable, and offer improved maintainability. With their wear-prone parts constructed of wear-resistant materials, they are also superbly durable. Moreover, the shaft incorporates Tsurumi's original agitator to prevent air lock as occasionally seen in vortex pumps and semi-vortex pumps. The agitator also stirs slurry efficiently.

The HSZ-series is made as a simple float switch-equipped automatic model to prevent dry-running operation and to reduce power consumption.

Max. capacity of  
**580 L/min**  
while operating  
at single-phase,  
**0.75 kW!**



HS3.75SL



HSZ3.75SL  
Automatic model

# HS3.75SL / HSZ3.75SL MODEL

# Features

## 1 Anti-wicking Cable Entry

Prevents water incursion due to capillary action should the cable sheath be damaged or the end of cable submerged. Also prevents moist air from infiltrating the motor housing and condensation from forming inside the housing due to temperature differences between the housing and outside air.

## 2 Dual Inside Mechanical Seals with Silicon Carbide Face

Eliminates problems like spring failure and ensures a long service life. Isolated in the oil chamber where a clean, non-corrosive and abrasion-free lubricating environment is maintained. The silicon carbide provides 5 times higher corrosion, wear and heat resistance than the tungsten carbide.

## 3 Oil Lifter

Provides lubrication and cooling of the seal faces down to 1/3 of normal oil level, thus maintaining a stable shaft sealing effect and prolonging seal life longer. The Oil Lifter is Tsurumi original design.

## 4 V-ring (0.75kW only)

Used as a "Dust Seal," they protect the mechanical seal from abrasive particles.

## 5 Agitator

Prevents the air lock that tends to take place on vortex or semi-vortex pumps.

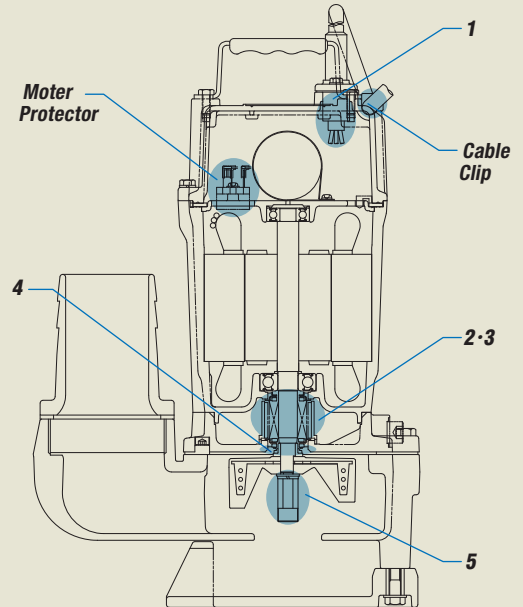

# Performance Curves

Standard and Automatic models have the identical performance.

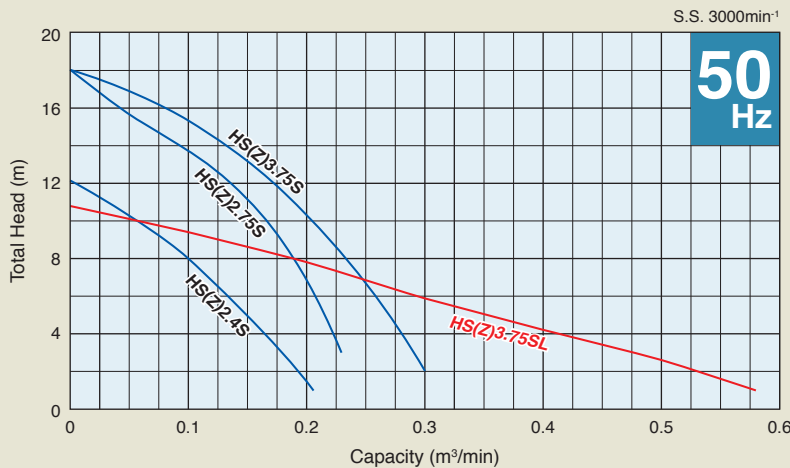

# Dimensions

Unit: mm

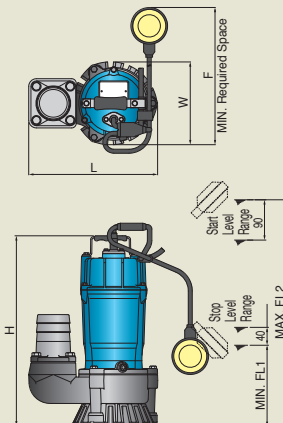

Model	F	FL1	FL2
HSZ2.4S	340	120	385
HSZ2.75S / HSZ3.75S	370	150	475
HSZ3.75SL	400	180	505

# Model Selection

Discharge Bore mm	Model		Motor Output kW	Phase	Starting Method	Solids Passage mm	Dimensions L x W x H mm	Dry Weight kg		Cable Length m
	Standard	Automatic						Standard	Automatic	
50	HS2.4S	HSZ2.4S	0.4	Single	Capacitor Run	7	241 x 184 x 328	11.3	11.3	5
50	HS2.75S	HSZ2.75S	0.75	Single	Capacitor Run	7	285 x 184 x 394	16.4	16.4	5
80	HS3.75S	HSZ3.75S	0.75	Single	Capacitor Run	7	285 x 184 x 394	16.8	16.8	5
80	HS3.75SL	HSZ3.75SL	0.75	Single	Capacitor Run	7	288 x 184 x 425	19.6	19.6	5

- Male threaded coupling for pipe connection available on special request
- Weights excluding cable

Product images and specifications may differ from actual products due to improvements. The OO series and model OO are indicated with our series/model codes in this catalog.

**TSURUMI**  
MANUFACTURING CO., LTD.

Your Dealer