

C

SEWAGE PUMPS  
WITH CUTTER IMPELLER



# Submersible Sewage Pumps with Cutter Impeller

Tsurumi C-series pumps are heavy-duty, submersible cutter pumps for sewage and wastewater, which are made of castings and equipped with cutting mechanism. Featuring a combination of impeller vane with brazed sintered tungsten carbide alloy edge and a suction cover of serrated shape, the C-series pumps enable smooth pumping, while cutting fibrous foreign objects during suction. These pumps have been used to drain sewage and wastewater from buildings and kitchens, and to transfer sewage and wastewater in water treatment facilities of factories and commercial complexes.

The C-series comes in a wide product lineup, covering discharge bore diameters of 50 to 200 mm and motor outputs of 0.75 to 37 kW. Among the C-series pumps, "CR" models are available as highly-durable cutter pumps, whose impeller and suction cover are made of high-chromium cast iron as a standard feature.

All models of the C-series can be used in combination with a guide rail fitting device that enables easy installation and maintenance. In addition, a new model of dry pit type is optionally available. The dry pit type pump can be installed indoors, and outside a tank. With Tsurumi's original specifications for dry pit, the dry pit pump delivers the performance of conventional submersible pumps in a variety of sites.

These pumps integrate original technologies that Tsurumi has researched and proven in the field over many years, such as anti-wicking cable, dual inside mechanical seals with silicone carbide face and Oil Lifter, etc.

Furthermore, durability and wear resistance have been thoroughly considered in their design, so these pumps enable continuous duty over long periods of time. Tsurumi products are designed to provide excellent durability and sound quality, thus contributing to the stable operation of facilities and enabling a considerable reduction in maintenance cost.

## Cutting various foreign objects with cutting mechanism



## Performance Range

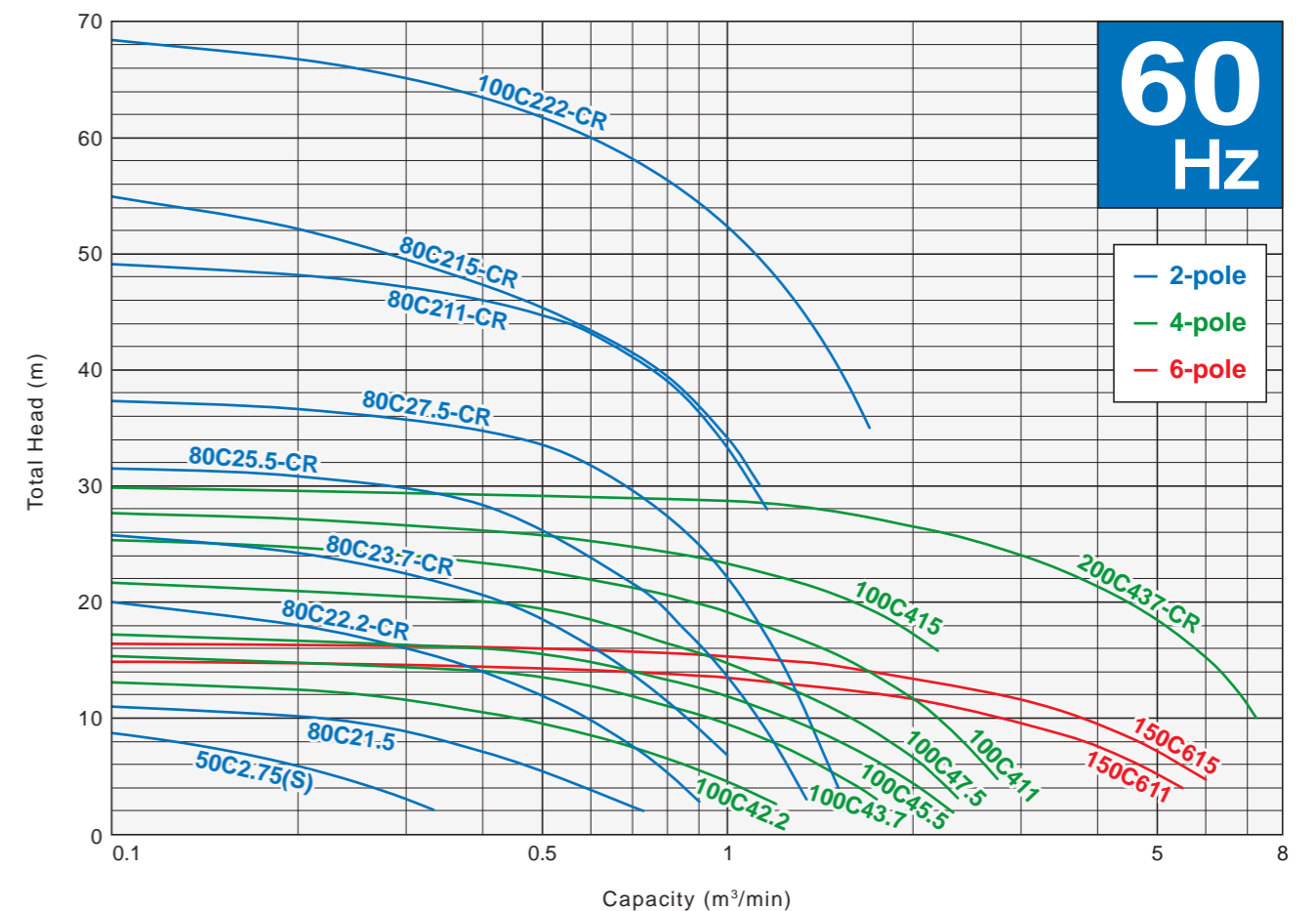
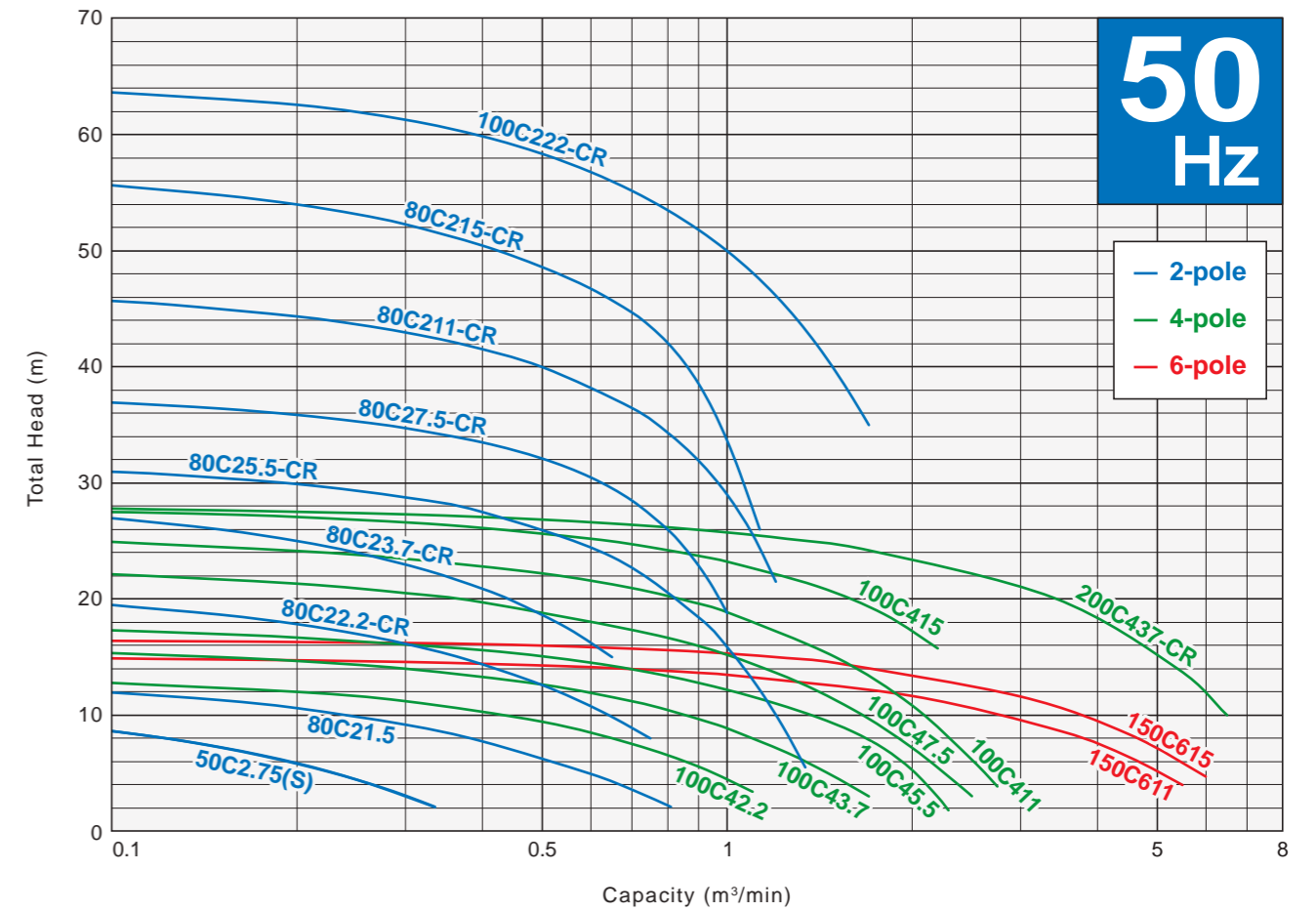

## Selection Table

		C (2-pole)	C (4-6-pole)
Discharge Bore	mm	50 – 100	100 – 200
Motor Output	kW	0.75 – 22	2.2 – 37
Impeller		<b>Cutter</b> (Channel Impeller with Cutting Edge)	
Leakage Sensor		● (Float type, 15 • 22kW only)	● (Electrode type, 37kW only)
Seal Pressure Relief Ports		● (5.5 – 22kW only)	● (37kW only)
Automatic or Auto-alternation Operation		● (0.75 • 1.5kW only)	
Guide Rail Fitting System		●	●
Page No.		9 - 10	11 - 12

Motor Output	0.75kW	1.5kW	2.2kW	3.7kW	5.5kW	7.5kW	11kW	15kW	22kW	37kW
2" 50mm	★									
3" 80mm		★	CR	CR	CR	CR	CR	CR		
4" 100mm									CR	
6" 150mm							CR	CR		
8" 200mm										CR

★: Automatic or Auto-alternation model available  
CR: Made of high-chromium cast iron impeller & suction cover

## Advanced Model "CR"

Among the C-series pumps, the "CR" models have been developed to transfer wastewater containing foreign matter efficiently and smoothly, while maintaining high head and high volume. Since high-chromium cast iron is used for the impeller and the suction cover, the "CR" model pumps provide high durability, and enable continuous duty over long periods of time.

Also, with other models, the impeller and suction cover material can be changed to high-chromium cast iron, as an option.

## Model Number Designation

TOS / TO: Guide rail fitting  
D : Dry pit

Made of high-chromium  
cast iron impeller & suction cover

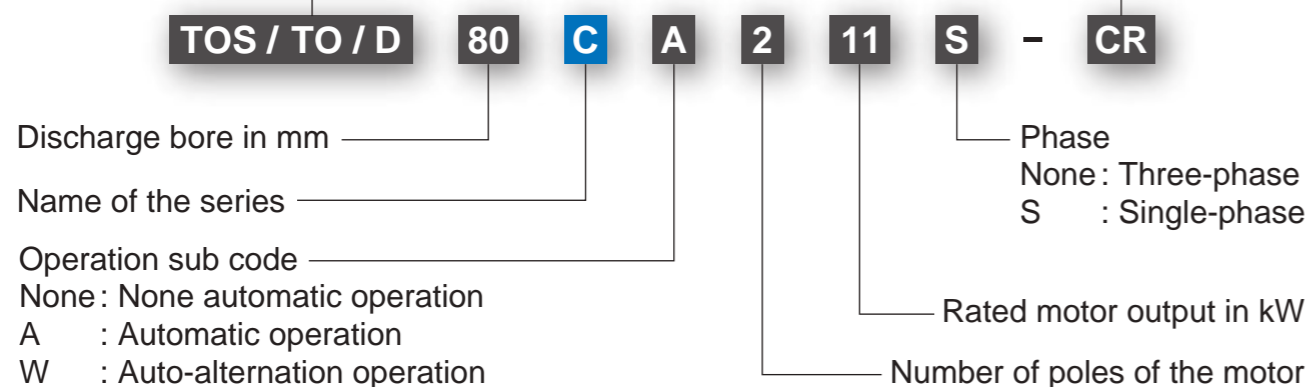

## Guide Rail Fitting System

The guide rail fitting system connects the pump to and from the piping easily just by lowering and hoisting the pump, allowing easy maintenance and inspection without the need to enter the sump. The TOS/TO is the guide rail fitting system made of cast iron and is compatible with cast iron pumps.

### Accessories

- Duckfoot Bend
- Guide Support
- Guide Hook
- Lifting Chain 5m (with Shackles)
- JIS 10kg/cm<sup>2</sup> Flange

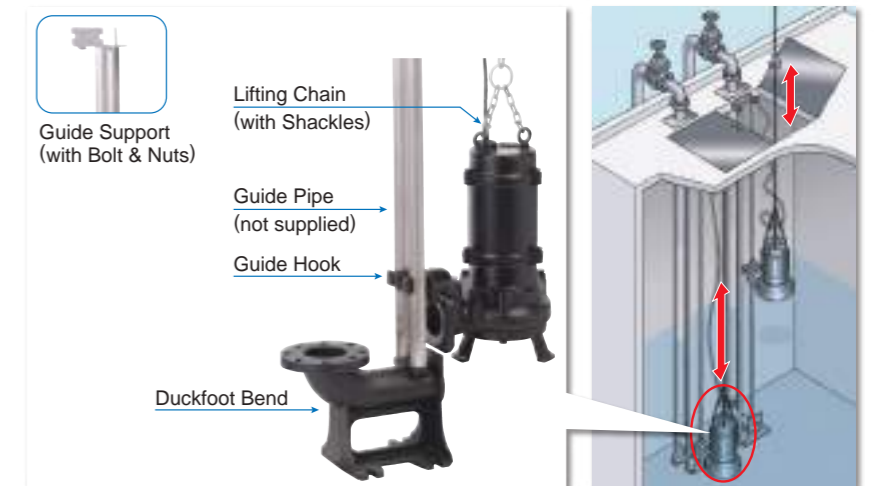

## Automatic & Auto-Alternation Model

Tsurumi offers an automatic alternation system by a duplex pump comprising an automatic model "A" unit and auto-alternation model "W" unit. The "A" unit is a stand-alone automatic pump and the "W" unit is a pump that has an alternating circuitry. All without the need of extra wiring, level sensors, or control panels.

### Automatic Model

The automatic model has an integral control circuit and two float switches that operate at a low voltage. It operates automatically in response to the change in water levels. This model can be identified by the suffix "A."

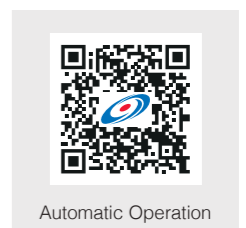

### Auto-Alternation Model

The auto-alternation model is used along with an automatic model. The combinational use of these two pumps enables each pump to operate alternately without control panel. This model can be identified by the suffix "W."



## Options

- Seawater-resistant version;** Galvanic anode & special Impeller
- High temperature liquids version;** Max. 90°C
- Special material version;** Made of high-chromium cast iron impeller & suction cover
- Dry pit version;** Available upon request

Model  
**100C47.5**

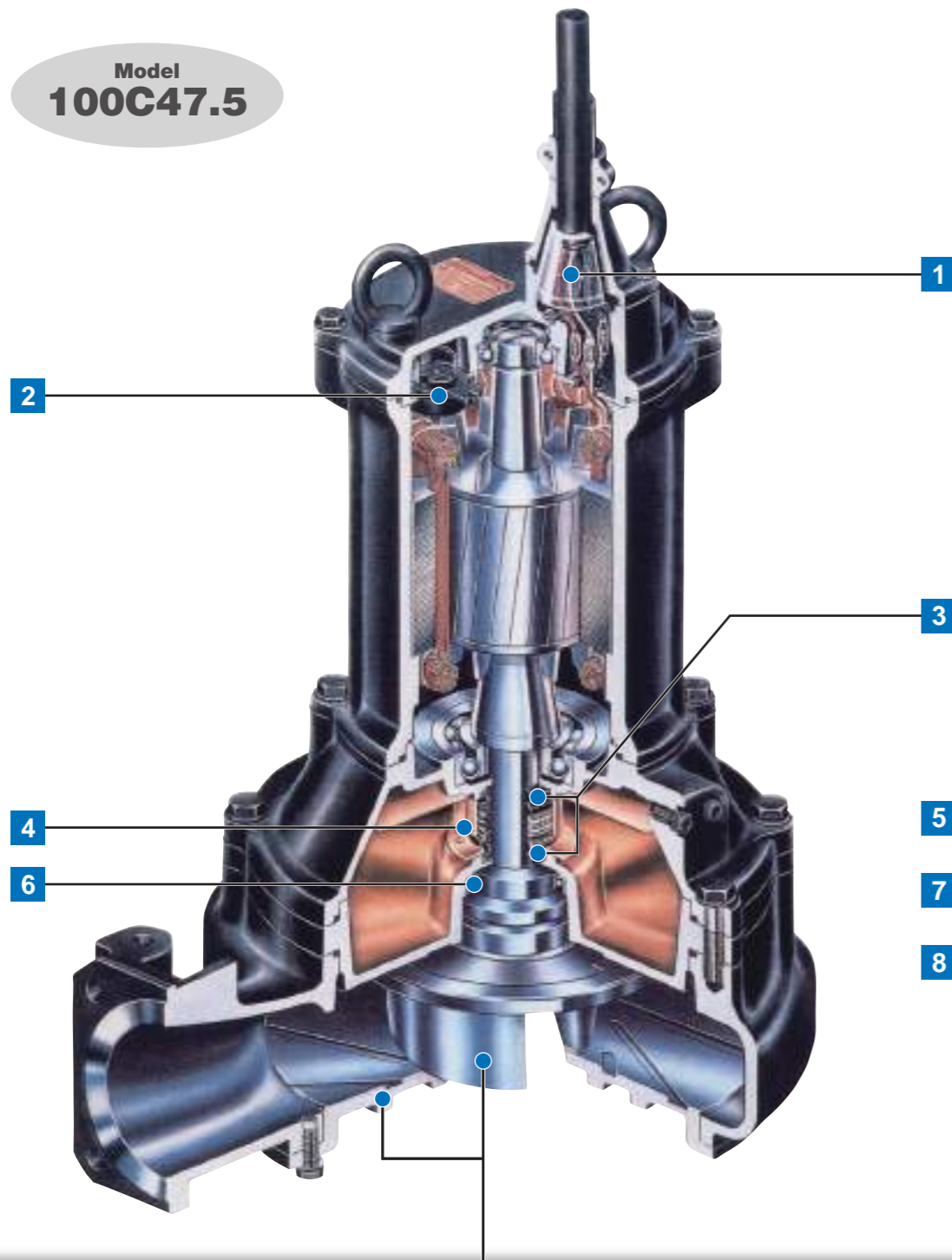

**1 Anti-wicking Cable Entry**

Prevents water incursion due to capillary action should the cable sheath be damaged or the end of cable submerged. Also prevents moist air from infiltrating the motor housing and condensation from forming inside the housing due to temperature differences between the housing and outside air.

**2 Motor Protector**

**Circle Thermal Protector** (7.5kW and below)

Directly cuts the motor circuit if excessive heat builds up or overcurrent occurs in the motor.

**Miniature Thermal Protectors** (11kW and above)

React to excessive heat caused by dry-running. The bimetal strip opens to cause the control panel to shut the power supply.

**3 Dual Inside Mechanical Seals with Silicon Carbide Faces**

Isolated in the oil chamber where a clean, non-corrosive and abrasion-free lubricating environment is maintained. Compared with the water-cooled outside mechanical seal, it reduces the risk of failure caused by dry-heating and adhering matter. The silicon carbide provides 5 times higher corrosion, wear and heat resistance than the tungsten carbide. Rubber parts of the upper and lower fixing rings are made of NBR or FPM (FKM), which provides higher resistance to heat and chemicals.

**4 Oil Lifter [Patented]**

Provides lubrication and cooling of the seal faces down to 1/3 of normal oil level, thus maintaining a stable shaft sealing effect and prolonging seal life longer.

**5 Leakage Sensor**

**Float Type** (80C215-CR and 100C222-CR)

**Electrode Type** (200C437-CR)

Detects flooding into the incursion water storage chamber and oil chamber that may occur in a worst case scenario. When flooding is detected, signals are sent to operate the indicator lamps through the external control panel.

**6 Oil Seal**

Used as a "Dust Seal," it protects the mechanical seal from abrasive particles.

**7 Seal Pressure Relief Port** (5.5kW and above of 2-pole, 200C437-CR)

Protects the mechanical seal from pump pressure. It also protects the seal face by discharging wear particles.

**8 Air Release Valve** \*excluding some models

Fitted on the pump casing to prevent the air lock. When air flows through the valve, the ball stays at the bottom, but when the pumped water starts to flow, the ball closes the outlet because of its buoyancy.

**Impeller & Suction Cover**

**CUTTING MECHANISM**

The cutter pump mechanism comprises a combination of impeller vanes with single or two brazed sintered tungsten carbide alloy edge and a suction cover of serrated shape. The front surface of the suction cover has numerous grooves that catch fibrous matter, which is then shredded by the tungsten carbide alloy edges of the impeller vanes and the saw teeth of the suction cover. This mechanism prevents the pump from being clogged with fibrous matter that can easily clog any pump.



**Sintered Tungsten Carbide Alloy Edge**

**Options**

**Seawater-Resistant Version**

In seawater, a material's resistance to corrosion can be seen clearly. When metals with different potentials are brought into contact in seawater, only the metal of lower potential corrodes. As the difference in potential increases, the metal of lower potential corrodes faster. As an option, Tsurumi can supply pumps with parts made of higher electric potential metal as the sacrificial anode.

**High Temperature Liquids Version**

Tsurumi's submersible pumps are applicable to high temperature liquids of up to 90°C. Pumps of the standard specification can discharge liquids of up to 40°C. However, there are many fields that need to discharge higher temperature liquids, e.g., discharging industrial water from a power plant or ironworks, or discharging hot spring water from a mine in a volcanic zone.

**Special Material Version**

Tsurumi can also provide you with pumps with essential components such as the impeller, pump casing and the suction cover made of non-standard materials. Select from stainless steel, high-chromium cast iron and bronze to suit your specific requirements.

**Special Option: Dry Pit Version**

**Developed with Tsurumi-original specifications, aiming for stable operation and reduction in maintenance labor.**

As a special option of the Tsurumi C-series cutter pumps, dry pit specifications are available. The dry pit pumps have been designed to drain wastewater from buildings, in which a mixture of all kinds of sewage and wastewater is expected.

The dry pit pumps can be installed indoors and outside of tanks, and still deliver the performance of conventional submersible pumps. Daily inspection and maintenance are easy, because the pump body is installed indoors.

These pumps have been developed with Tsurumi-original specifications, aiming for stable operation and reduction in maintenance labor. Of course, the dry pit pumps inherit the anti-wicking cable, dual inside mechanical seals with silicone carbide faces on the sides that are not in contact with wastewater, and Oil Lifter from Tsurumi's submersible pumps. In addition, they are designed with the maximum consideration for high-temperature resistance, with bearing grease for high temperature use, class H insulation, a leakage sensor, mechanical seals made of FPM (FKM), and high-grade lubricating oil as standard specifications. Pump models of 7.5 kW or lower motor output come without a water jacket, while the models of 11 kW or higher motor output are equipped with a water jacket as a standard feature.

As the most advanced feature of the 11 kW or higher output models, a wear ring is provided to prevent waste from clogging in the water jacket. Thus, solids can enter the water jacket only through the minute clearance between the impeller and the wear ring. This structure is a Tsurumi-original design.

As described above, Tsurumi's dry pit pumps feature a high quality, highly-reliable design that ensures excellent durability and high wear resistance. They can be installed in a variety of sites and will help keep facilities operating stably and will remarkably reduce maintenance costs.

**Pump models of 7.5kW and below without Water Jacket**

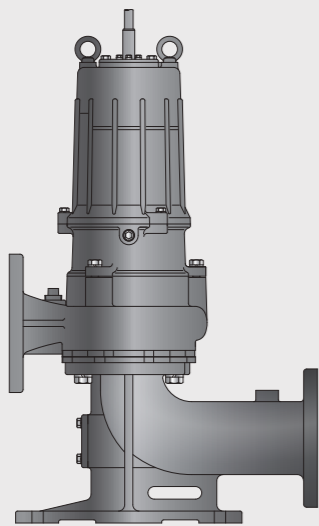

**Pump models of 11kW and above with Water Jacket**

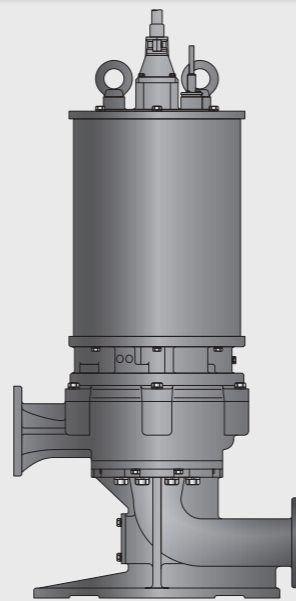

**Model D100C415**

- Standard Specifications
- Special Specifications for Dry Pit Version

**Anti-wicking Cable Entry**

**Bearing**

Bearing grease for high temperature use

**Motor Protector**

**Leakage Sensor**

- Electrode Type (7.5kW and below)
- Float Type (11kW and above)

**Water Jacket (11kW and above)**

The motor is cooled by a water jacket assuring efficient motor cooling even when the pump operates with its motor exposed to air.

**Dual Inside Mechanical Seals with Silicon Carbide Faces**

Rubber parts are made of FPM (FKM) which provides high resistance to heat and chemicals.

**Motor**

Class H insulation

**Oil Lifter [Patented]**

**Wear Ring (11kW and above)**

The wear ring is provided to prevent waste from clogging in the water jacket.

**Lubricating Oil**

Turbine oil (ISO VG56), high-grade lubricating oil

**Oil Seal**

**Cleaning Cover**

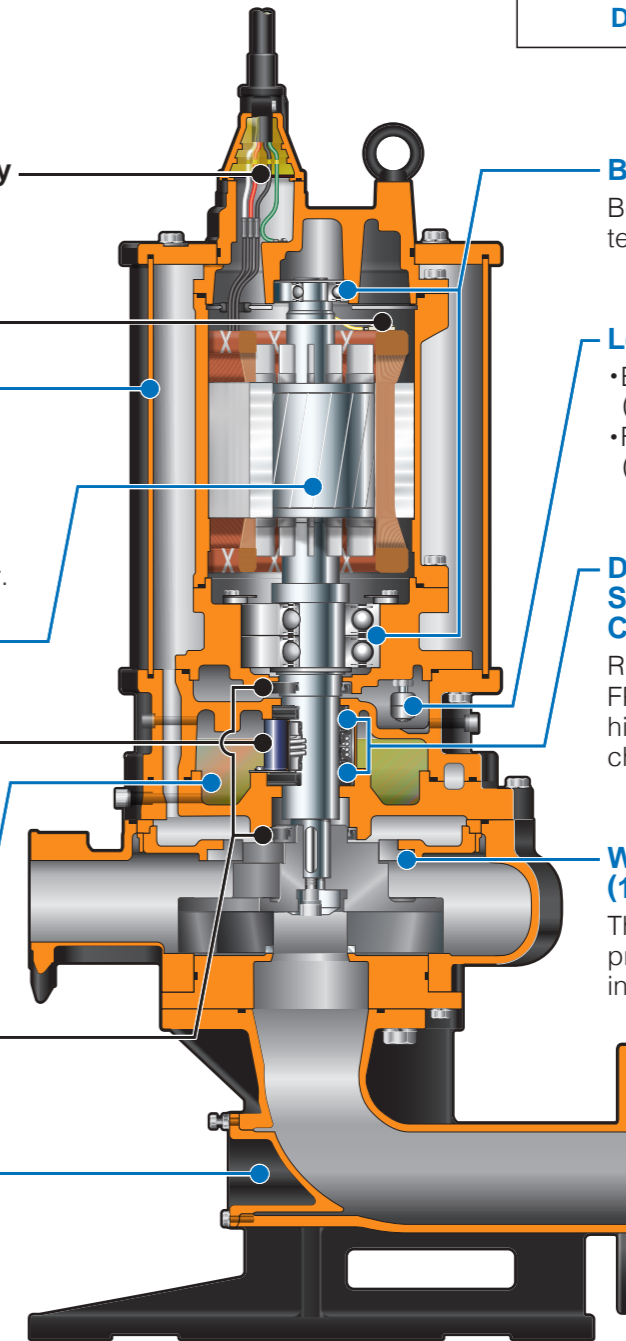

**Example of Installation**

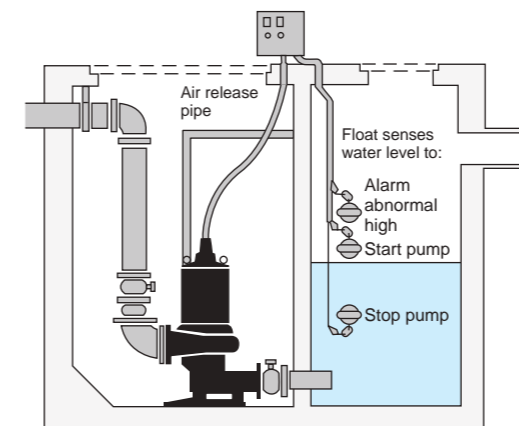

# C (2-pole) –Cutter Impeller–

The C-series is a submersible cutter pump designed for handling raw sewage, wastewater, and heavy-duty industrial applications, where the pump is subject to clogging from oversize material. Single or two tungsten carbide alloy edge blazed on the impeller vane on the serrated suction cover. This mechanism cuts incoming fibrous material into pieces, permitting smooth passage of fibrous material. The impeller and suction cover of the “CR” type are made of high-chromium cast iron, ensuring excellent durability and enabling the pump to maintain high performance for an extended period.



## Performance Curves

< 0.75 - 7.5kW >

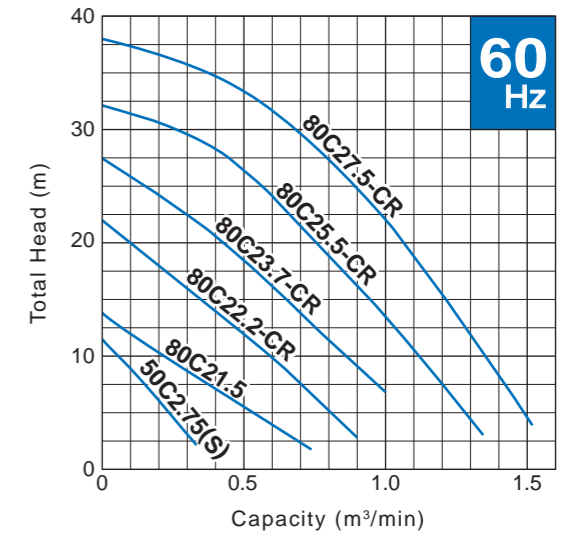
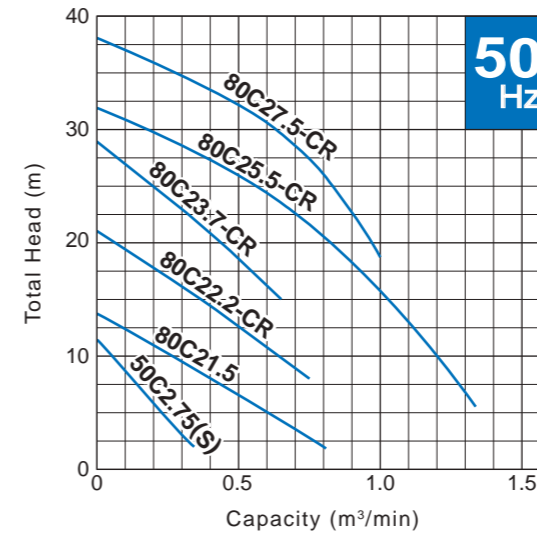

< 11 - 22kW >

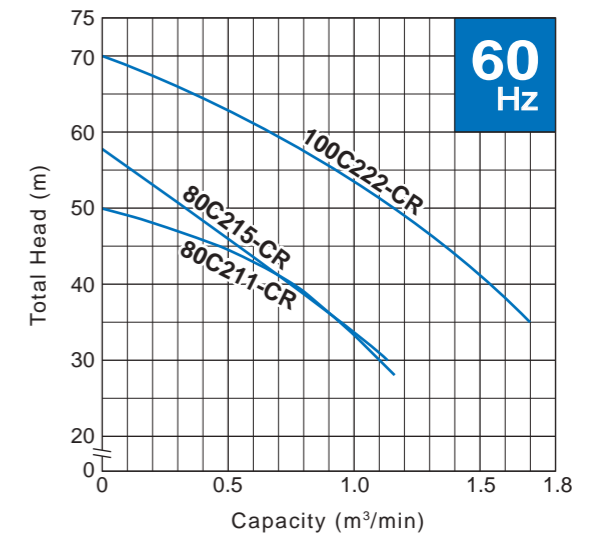
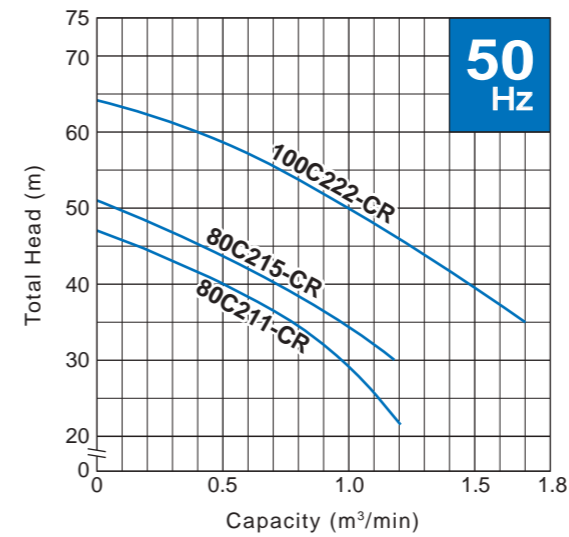

Discharge Bore mm	Standard Model		Automatic Model		Auto-Alternation Model		Motor Output kW	Phase	Starting Method	Dimensions L x H mm				Dry Weight*2 kg				Cable Length m
	Free Standing	Guide Rail Fitting	Free Standing	Guide Rail Fitting	Free Standing	Guide Rail Fitting				Standard Model		Auto& Auto-Alternation Model		Standard Model		Auto& Auto-Alternation Model		
										Free Standing	Guide Rail Fitting	Free Standing	Guide Rail Fitting	Free Standing	Guide Rail Fitting	Free Standing	Guide Rail Fitting	
50	50C2.75S	TOS50C2.75S	50CA2.75S	TOS50CA2.75S	—	—	0.75	Single	Capacitor Start	405 x 523	621 x 566	405 x 580	621 x 624	32	30	34	32	5
50	50C2.75	TOS50C2.75	50CA2.75	TOS50CA2.75	50CW2.75	TOS50CW2.75	0.75	Three	D.O.L.	405 x 415	621 x 458	433 x 496	649 x 539	24	23	25	24	6
80	80C21.5	TOS80C21.5	80CA21.5	TOS80CA21.5	80CW21.5	TOS80CW21.5	1.5	Three	D.O.L.	446 x 536	668 x 586	485 x 630	707 x 680	36	34	40	38	6
80	80C22.2-CR	TOS80C22.2-CR	—	—	—	—	2.2	Three	D.O.L.	519 x 611	693 x 640	—	—	70	64	—	—	10
80	80C23.7-CR	TOS80C23.7-CR	—	—	—	—	3.7	Three	D.O.L.	519 x 613	693 x 640	—	—	70	64	—	—	10
80	80C25.5-CR	TOS80C25.5-CR	—	—	—	—	5.5	Three	D.O.L.*1	615 x 879	788 x 877	—	—	125	123	—	—	10
80	80C27.5-CR	TOS80C27.5-CR	—	—	—	—	7.5	Three	D.O.L.*1	615 x 879	788 x 877	—	—	130	128	—	—	10
80	80C211-CR	TOS80C211-CR	—	—	—	—	11	Three	Star-Delta	615 x 927	788 x 925	—	—	160	152	—	—	10
80	80C215-CR	TOS80C215-CR	—	—	—	—	15	Three	Star-Delta	730 x 1086	937 x 1086	—	—	260	235	—	—	10
100	100C222-CR	TOS100C222-CR	—	—	—	—	22	Three	Star-Delta	837 x 1184	1025 x 1184	—	—	420	380	—	—	10

\*1 Star-Delta available upon request

\*2 All weights excluding cable

Weights of guide rail fitting excluding duckfoot bend

## Dimensions

Free Standing

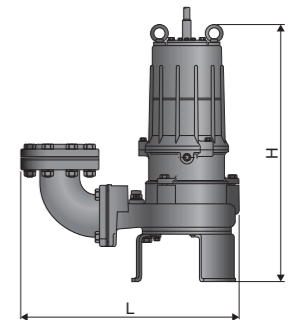

Guide Rail Fitting

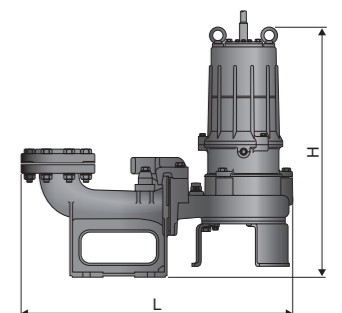

# C (4·6-pole) –Cutter Impeller–

The C-series is a submersible cutter pump designed for handling raw sewage, wastewater, and heavy-duty industrial applications, where the pump is subject to clogging from oversize material. Single or two tungsten carbide alloy edge blazed on the impeller vane on the serrated suction cover. This mechanism cuts incoming fibrous material into pieces, permitting smooth passage of fibrous material. The impeller and suction cover of the “CR” type are made of high-chromium cast iron, ensuring excellent durability and enabling the pump to maintain high performance for an extended period.



Discharge Bore mm	Model		Motor Output kW	Phase	Starting Method	Dimensions L x H mm		Dry Weight*2 kg		Cable Length m
	Free Standing	Guide Rail Fitting				Free Standing	Guide Rail Fitting	Free Standing	Guide Rail Fitting	
100	100C42.2	TOS100C42.2	2.2	Three	D.O.L.	596 x 641	754 x 656	68	64	6
100	100C43.7	TOS100C43.7	3.7		D.O.L.	601 x 715	759 x 725	84	80	6
100	100C45.5	TOS100C45.5	5.5		D.O.L.*1	686 x 908	905 x 906	133	126	8
100	100C47.5	TOS100C47.5	7.5		D.O.L.*1	686 x 929	905 x 927	144	137	8
100	100C411	TOS100C411	11		Star-Delta	709 x 1000	928 x 998	179	172	8
100	100C415	TOS100C415	15		Star-Delta	707 x 1080	926 x 1078	221	201	8
150	150C611-CR	TOS150C611-CR	11		Star-Delta	1043 x 1211	1237 x 1126	430	390	8
150	150C615-CR	TOS150C615-CR	15		Star-Delta	1043 x 1261	1228 x 1176	500	410	8
200	200C437-CR	TO200C437-CR	37		Star-Delta	1190 x 1588	1428 x 1408	660	555	10

\*1 Star-Delta available upon request

\*2 All weights excluding cable

Weights of guide rail fitting excluding duckfoot bend

## Performance Curves

< 4-pole 2.2 - 15kW >

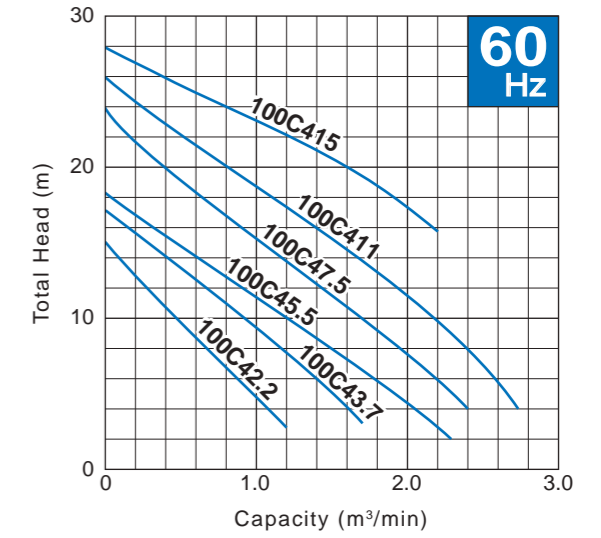
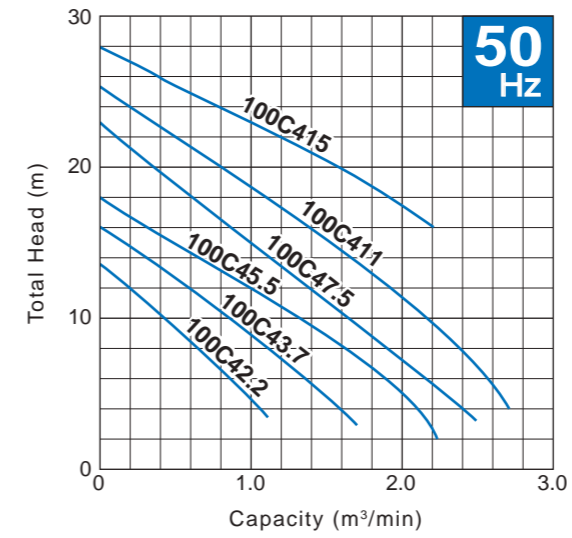

< 4-pole 37kW, 6-pole 11·15kW >

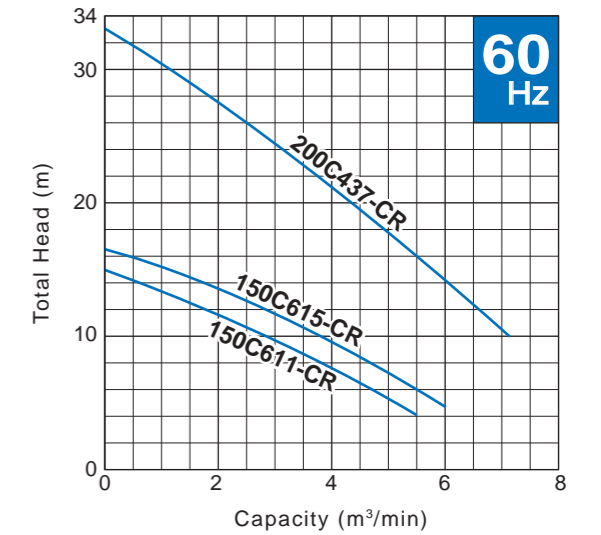
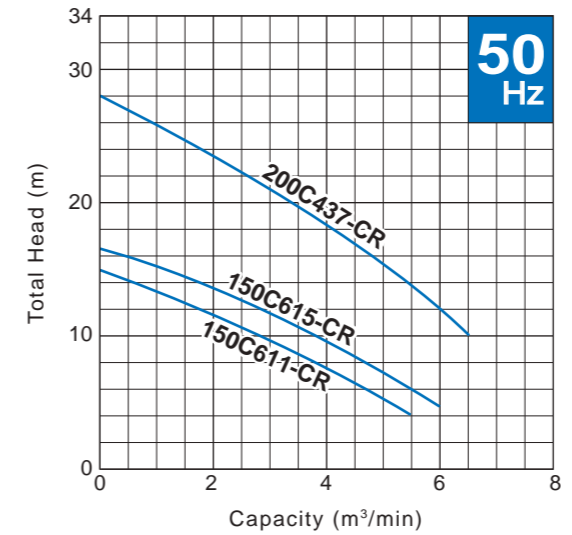

## Dimensions

Free Standing

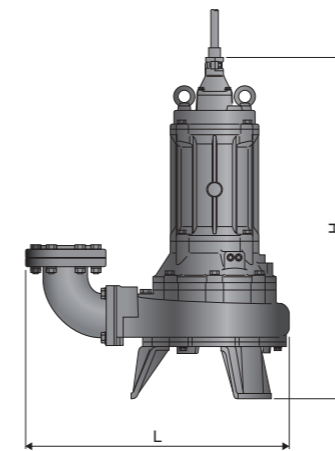

Guide Rail Fitting

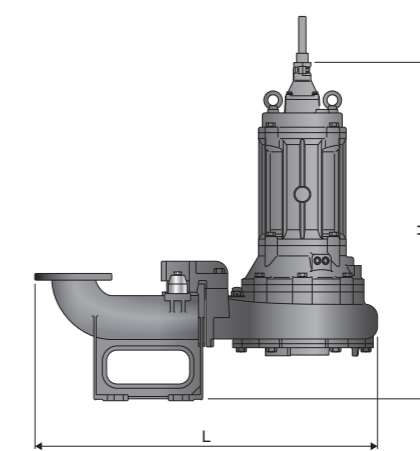

# Specifications

		C (2-pole)										C (4 · 6-pole)														
		50C2.75S (50CA2.75S)	50C2.75 (50CA2.75 50CW2.75)	80C21.5 (80CA21.5 80CW21.5)	80C22.2-CR	80C23.7-CR	80C25.5-CR	80C27.5-CR	80C211-CR	80C215-CR	100C222-CR		100C42.2	100C43.7	100C45.5	100C47.5	100C411	100C415	150C611-CR	150C615-CR	200C437-CR					
PUMP	Discharge Bore mm	50			80						100		100										150		200	
	Discharge Connection	Threaded Oval Flange			JIS 10kg/cm <sup>2</sup> Flange										JIS 10kg/cm <sup>2</sup> Flange											
	Impeller	Cutter (Semi-open Single-channel Impeller with Cutting Edge)			Cutter (Semi-open Two-channel Impeller with Cutting Edges)										Cutter (Semi-open Single-channel Impeller with Cutting Edge)					Cutter (Semi-open Two-channel Impeller with Cutting Edges)						
		Gray Cast Iron with Tungsten Carbide Alloy			High-chromium Cast Iron with Tungsten Carbide Alloy										Gray Cast Iron with Tungsten Carbide Alloy					High-chromium Cast Iron with Tungsten Carbide Alloy						
	Suction Cover	Ductile Cast Iron			High-chromium Cast Iron										Ductile Cast Iron					High-chromium Cast Iron						
	Oil Seal	Nitrile Butadiene Rubber										Nitrile Butadiene Rubber					—					Nitrile Butadiene Rubber				
	Casing	Gray Cast Iron										Gray Cast Iron														
	Shaft Seal	Dual Inside Mechanical Seals (with Oil Lifter)										Dual Inside Mechanical Seals (with Oil Lifter)														
Silicon Carbide										Silicon Carbide																
MOTOR	Type	Continuous-duty Rated, Dry-type Induction Motor										Continuous-duty Rated, Dry-type Induction Motor														
	Output kW	0.75		1.5	2.2	3.7	5.5	7.5	11	15	22		2.2	3.7	5.5	7.5	11	15	11	15	37					
	Phase	Single		Three										Three												
	Pole	2										4					6		4							
	Speed (S.S.) 50/60Hz min <sup>-1</sup>	3000/3600										1500/1800										1000/1200		1500/1800		
	Insulation	E		F										E		F					B		F			
	Starting Method	Capacitor Start	D.O.L.			D.O.L.* <sup>2</sup>			Star-Delta				D.O.L.		D.O.L.* <sup>2</sup>			Star-Delta								
	Motor Protector (built-in)	CTP					MTP					CTP					MTP									
	Leakage Sensor (built-in)	—					Float					—										Electrode				
	Lubricant ml	590	440	900	1890		2240			3300	3400		1350		4200	4800	6500	5500	6000		9500					
		Turbine Oil (ISO VG32)										Turbine Oil (ISO VG32)														
	Frame	Gray Cast Iron										Gray Cast Iron														
	Shaft	420 Stainless Steel										420 Stainless Steel														
Power Cable m	5	6		10						6		8					10									
	PVC					Chloroprene Rubber					PVC		Chloroprene Rubber													
Dry Weight **	Free Standing kg	32	24	36	70	125	130	160	260	420		68	84	133	144	179	221	430	500	660						
	Guide Rail Fitting kg	30	23	34	64	123	128	152	235	380		64	80	126	137	172	201	390	410	555						

\*1 All weights excluding cable  
Weights of guide rail fitting excluding duckfoot bend

\*2 Star-Delta available upon request



We reserve the right to change the specifications and designs for improvement without prior notice.

**TSURUMI  
MANUFACTURING CO., LTD.**

Your Dealer