



Submersible Wastewater Pumps *Semi-open Impeller*

SF



Features

SF

The SF-series is a cast iron, compact, efficient pump having a semi-open impeller. It is designed for high-head pumping plus defaming at wastewater treatment plants.

Motor Protector

All Tsurumi pumps have a built-in motor protection device. A circle thermal protector (CTP) is incorporated in Tsurumi pumps with a direct-on-line starting motor. The CTP is installed in the motor housing and it directly cuts the motor circuit if excessive heat builds up or an over-current is caused by an electrical or mechanical failure.

Pumps with a star-delta starting motor have three miniature thermal protectors (MTPs) imbedded in each winding of the 3-phase motor. These MTPs are connected in series, with their wires led out of the motor. Should the windings temperature rise to the actuating level, the bimetal strip opens to cause the control panel to shut down the power supply.

Oil Lifter (Patented)

The Oil Lifter was developed as a lubricating device for the mechanical seal. Utilizing the centrifugal force of the shaft seal, the Oil Lifter forcibly supplies lubricating oil to the mechanical seal and continues to supply the oil to the upper seal faces even if lubricant falls below the rated volume. This amazingly simple device is not only reliably lubricates and cools down, but also retains the stable shaft seal effect and extends the inspection term.

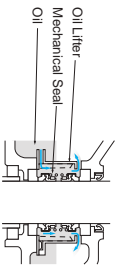

Cable Entry

Every cable/ye cable has an anti-wicking block at the cable entry section of the pump. This mechanism is such that a part of each conductor is stripped back and the part is sealed by molded rubber or epoxy potting which has flowed in between each strand of the conductor. This unique feature prevents wicking along the strand of the conductor itself.

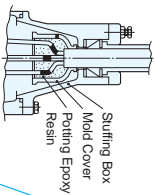

Motor

The motor is a dry-type, squirrel-cage induction motor, housed in a water-tight casing, and conforms to insulation classes E or F. In each of these insulation classes, all standard pumps can be used in ambient temperatures up to 40°C.

Mechanical Seal

The mechanical seal with two seal faces containing silicon carbide (SiC) is equipped with the oil chamber. The advantages of the seal are two-fold. It eliminates spring failure caused by corrosion, abrasion or fouling which prevents the seal faces from closing properly, and prevents loss of cooling to the lower seal faces during run-dry conditions which causes the lower seal faces to fail.

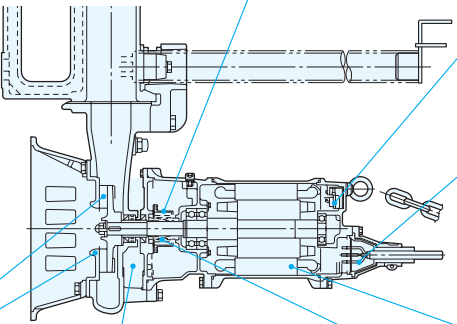

Guide Rail Fitting System

Guide rail fitting system readily connect/disconnect the pump to/from the piping system only by lifting up and down the pump. This simplifies regular maintenance and inspection, which will no longer require entry into the sump. The SF-series pumps with capacity of 1.5 kW to 11 kW, preceded by TOS in the model code, are available with guide rail fittings. For more information about model codes, see the Model Selection.

Replaceable Wear Parts

All these pumps are designed so that their wear parts, such as the impeller and the suction cover, can be replaced by new ones very easily.

Applications:

- Draining treated water at wastewater treatment plant
- Pumping rainwater and springwater from underground
- Supplying treated water for deforming at wastewater treatment plant

Technical Data

SF

Model Number Designation

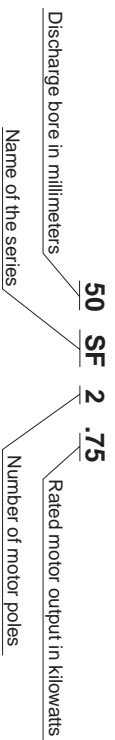

Performance Curves

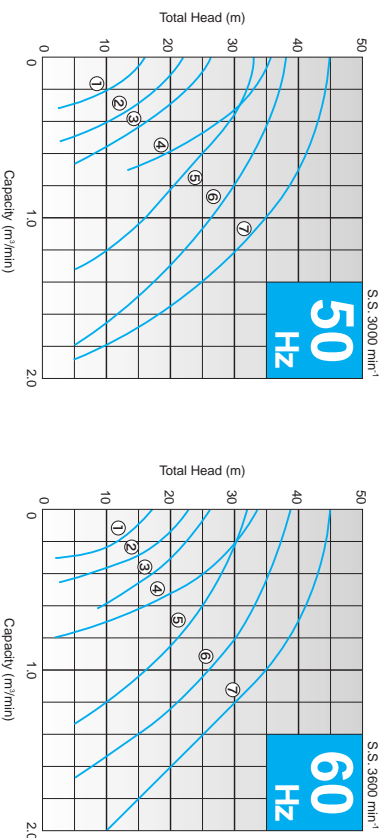

Model Selection 50/60Hz

| Curve No. | Discharge Bore mm | Model | Motor Output kW | Phase | Speed (S.S.) min ⁻¹ | Starting Method | Solids Passage mm | Cable Length m | Cable Code | Dimensions L × H | | | Dry Weight ^{*)} kg |
|-----------|-------------------|--------------------|-----------------|-------|--------------------------------|-----------------|-------------------|----------------|------------|------------------|--------------------|---------------|-----------------------------|
| | | | | | | | | | | Free Standing | Guide Rail Fitting | Free Standing | |
| 1 | 50 | 50SF2.75 (TOK) | 0.75 | Three | 3000/3600 | D.O.L. | 11/10 | 6 | A | 256 × 377 | — | 20 | — |
| 2 | 50 | 50SF21.5 | 1.5 | Three | 3000/3600 | D.O.L. | 11/10 | 6 | A | 421 × 494 | 637 × 542 | 33 | 32 |
| 3 | 50 | 50SF22.2 | 2.2 | Three | 3000/3600 | D.O.L. | 7.5 | 6 | A(C*) | 466 × 534 | 648 × 582 | 49 | 48 |
| 4 | 50 | 50SF23.7 | 3.7 | Three | 3000/3600 | D.O.L. | 7.5 | 6 | C(E*) | 466 × 537 | 648 × 585 | 59 | 58 |
| 5 | 80 | 80SF25.5 | 5.5 | Three | 3000/3600 | D.O.L.* | 15/19 | 8 | H | 635 × 824 | 808 × 855 | 125 | 122 |
| 6 | 80 | 80SF27.5 | 7.5 | Three | 3000/3600 | D.O.L.* | 19/21 | 8 | I | 635 × 824 | 808 × 855 | 128 | 125 |
| 7 | 80 | 80SF211 TOS80SF211 | 11 | Three | 3000/3600 | Star-Delta | 22 | 8 | R | 635 × 872 | 808 × 903 | 147 | 144 |

* Star-Delta available upon request * 200-240V
 *) All weights excluding cable
 † Weights of guide rail fitting model excluding duckfoot bend

Notes:
 When an SF pump is ordered with guide rail fitting*, the following accessories will come with the pump as standard equipment (* Attach TOS to its model code.):

- Contents of TOS**
- Lifting Chain 5m (with Shackles)
 - Guide Support (with Bolts & Nuts)
 - Guide Hook (with Bolts)
- Dimensions**
- Duckfoot Bend
 - JIS 10kg/cm² Flange (with Packing, Bolts & Nuts)

Dimensions

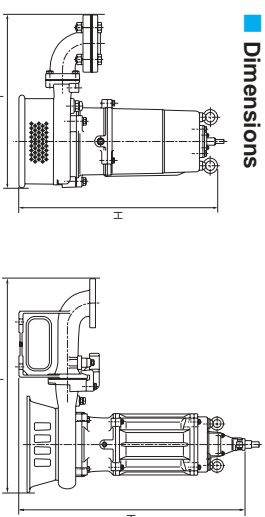

Cable/ye Cable Code Reference

| Code | Res/Unit | Cores × mm ² | Dia. mm | Material |
|------|----------|-------------------------|---------|--------------------|
| A | 1 | 4 × 1.25 | 11.1 | PVC |
| C | 1 | 4 × 2 | 11.8 | |
| E | 1 | 4 × 3.5 | 13.9 | |
| H | 1 | 4 × 3.5 | 14.1 | |
| I | 1 | 4 × 5.5 | 16.8 | |
| R | 3 | 4 × 3.5 | 14.1 | Chloroprene Rubber |
| | | 3 × 3.5 | 12.9 | |
| | | 2 × 1.25 | 9.8 | |

Tsurumi Float Switch

Model MC-2 is a heavy-duty float switch with a shock absorber. Equipped with a high-grade micro-switch, the float assures trouble-free pump operation in the sewage or liquid containing suspended solids and floating scum. The MC-2 has both normally open and normally close contacts as standard. You can select either of the two contacts as required.



Model RF-5 is an economy float switch which can detect upper/lower limit water levels with a single float. The snap on-off action ensures stable pump operation in the clean or waste water containing suspended solids or oil and fat.



TOK Guide Rail Fitting System

Tsurumi provides TOK-type guide rail fitting system, as an option, for Model 50SF2.75. The fittings connect/separate the pump to/from piping only by lifting up and down the pump; no need to enter the sump for maintenance.



The TOK is supplied with the following contents:

- Lifting Chain 4m (with Shackles)
- Guide Support (with Bolts & Nuts)
- Guide Hook
- Duckfoot Bend

Tsurumi Options

Special Version with Galvanic Corrosion Protection

In seawater, a material's resistance to corrosion can be seen clearly. When metals with different potentials are brought into contact in seawater, only the metal of lower potential corrodes. As the difference in potential increases, the metal of lower potential corrodes faster. As an option, Tsurumi can supply pumps with parts made of higher electric potential metal as the sacrificial anode.

Special Version for High Temperature Liquid

Standard pumps are designed for continuous running at a maximum ambient temperature of 40°C. In addition to these, Tsurumi can provide pumps for operation at higher liquid temperature upon request. Refitting for operation at higher temperature involves modification of not only the insulation of motor windings but also several components. Two high-temperature operation models are available - the Rank 60 for operation in liquid up to 60°C and the Rank 90 for operation in liquid up to 90°C. Consult your dealer for more details. (These special versions are not available for some pump models.)

Special Version with Non-standard Materials

Tsurumi also offers pumps with essential components, such as the impeller, pump casing and suction cover, made of non-standard materials. Select from stainless steel, chromium iron and bronze to suit specific requirements. Please consult your dealer for more information.

We reserve the right to change the specifications and designs for improvement without prior notice.

**TSURUMI
MANUFACTURING CO., LTD.**

Your Dealer