

TSURUMI AVANT

SERIES

MY

SUBMERSIBLE
SEWAGE PUMPS



TSURUMI AVANT

“TSURUMI AVANT” is a new brand of submersible pump developed with an eye on the future by TSURUMI, a leading company in the field of submersible pumps for over 95 years. Created to deliver the maximum in customer satisfaction, the brand pools Tsurumi’s years of know-how with submersible pumps and completely revamps everything from the product lineup to the materials used for components into the highest grade of pumps it makes. We are releasing the new brand under the name of “TSURUMI AVANT.”



MY-series

Motors

from 1.5 to 18.5 kW operating at 50 Hz and 60 Hz
double mechanical seal in oil chamber

Hydraulics

- open channel (MYB)
- vortex (MYU)
- grinder (MYG)
- high head (MYS)

The MY-series of the “TSURUMI AVANT” brand features high grade submersible sewage pumps that Tsurumi makes. Designed and built with a heavy emphasis on durability and pumping efficiency, these high quality pumps are more reliable and run more stably than similar class pumps. Moreover, to ensure users get what they are looking for, the MY-series offers 4 types of impellers (Open Channel, Vortex, Grinder and High Head) and a versatile range of specifications featuring 40 to 250 mm discharge bore diameters and 1.5 to 18.5 kW motor output specifications. A wide lineup of 2-pole motors that deliver the performance needed in high head applications is also available.

Characteristics

- Cast iron structure
- Three-phase motor from 1.5 to 18.5 kW
- Insulation: class H (180°C)
- Protection rating: IP68
- 50 Hz and 60 Hz versions
- Thermal protection devices incorporated in stator
- AISI 431 drive shaft
- Two silicon carbide mechanical seals in large oil chamber
- Discharge from DN32 to DN250
- Large free passage



Overview of operating ranges

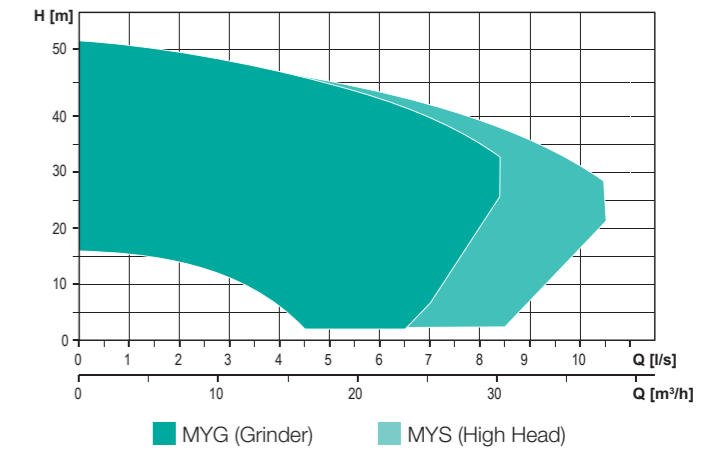
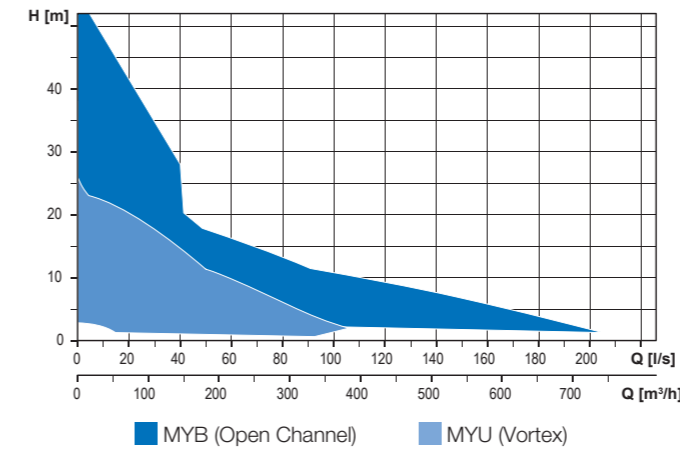

Construction materials

Motor casing	Cast iron GJL-250
Impeller	Cast iron GJL-250
Mechanical seals	Two in silicon carbide (2SiC)
Nuts and bolts	Stainless steel - class A2-70
Standard gaskets	NBR
Drive shaft	AISI 431 Stainless Steel
Chopper knife	Chromium steel (MYG)
Painting	Bicomponent epoxy paint with high resistance to corrosion

Operating specifications

Max operating temperature	40°C
pH of liquid	6 - 14
Max submergence	20 m
Liquid density	1.1 kg/dm ³
Max acoustic pressure	<70 dB
Max. starts/hour	20 (<10 kW) 15 (>10 kW)

The data provided are not binding. Tsurumi reserves the right to modify any product without notice.

Installations and accessories

A full range of **accessories** supplied as standard simplifies any **installation**

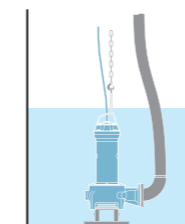

Hose Connection

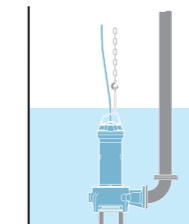

Free Standing

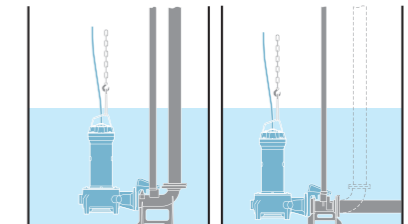

Guide Rail Fitting



- Guide rail fitting devices**
- Cast iron body - steel metal fasteners
 - Vertical and horizontal discharge
 - DN 65 - DN 250



- Discharge bends**
- In cast iron or galvanised steel
 - Full free passage
 - DN 65 - DN 250



- Ball check valves**
- Cast iron body - steel metal fasteners
 - Rubber ball
 - DN 65 - DN 250



- Base plates**
- In cast iron or galvanized steel
 - Ideal for free installation



- Gate valves**
- Cast iron body with bronze seats
 - Full free passage



- Chains**
- In stainless and galvanized steel
 - Ø 5mm, 8mm, 12mm



Features

HANDLE

Rugged stainless steel lifting and carrying handle

CABLE GLAND

The universal GAS thread of the cable gland is able to take a sheathing pipe to protect the power cable from mechanical or chemical damage due to turbulence or the aggressive nature of the liquid.

PRESSURISED TESTING

Every model undergoes pressurised testing to guarantee perfect assembly and operation of the gaskets, cable gland and mechanical seals.

MECHANICAL SEALS

Double mechanical seals in silicon carbide (SiC-SiC) enclosed in an inspectable oil chamber. This prevents all contact between the mechanical seals and any solids or filaments in the wastewater.

OIL CHAMBER

Large, inspectable oil chamber to guarantee longer mechanical seal lifetime. Leakage detection sensor.

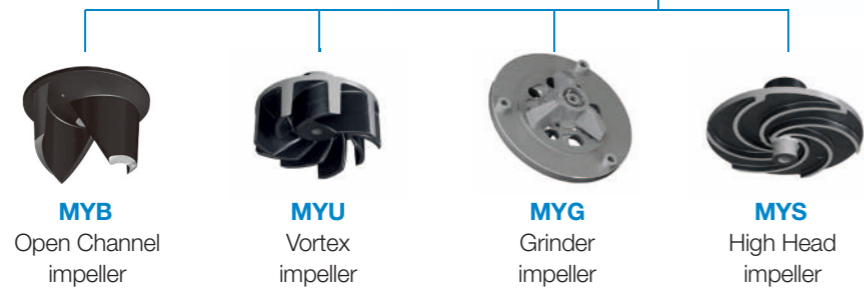
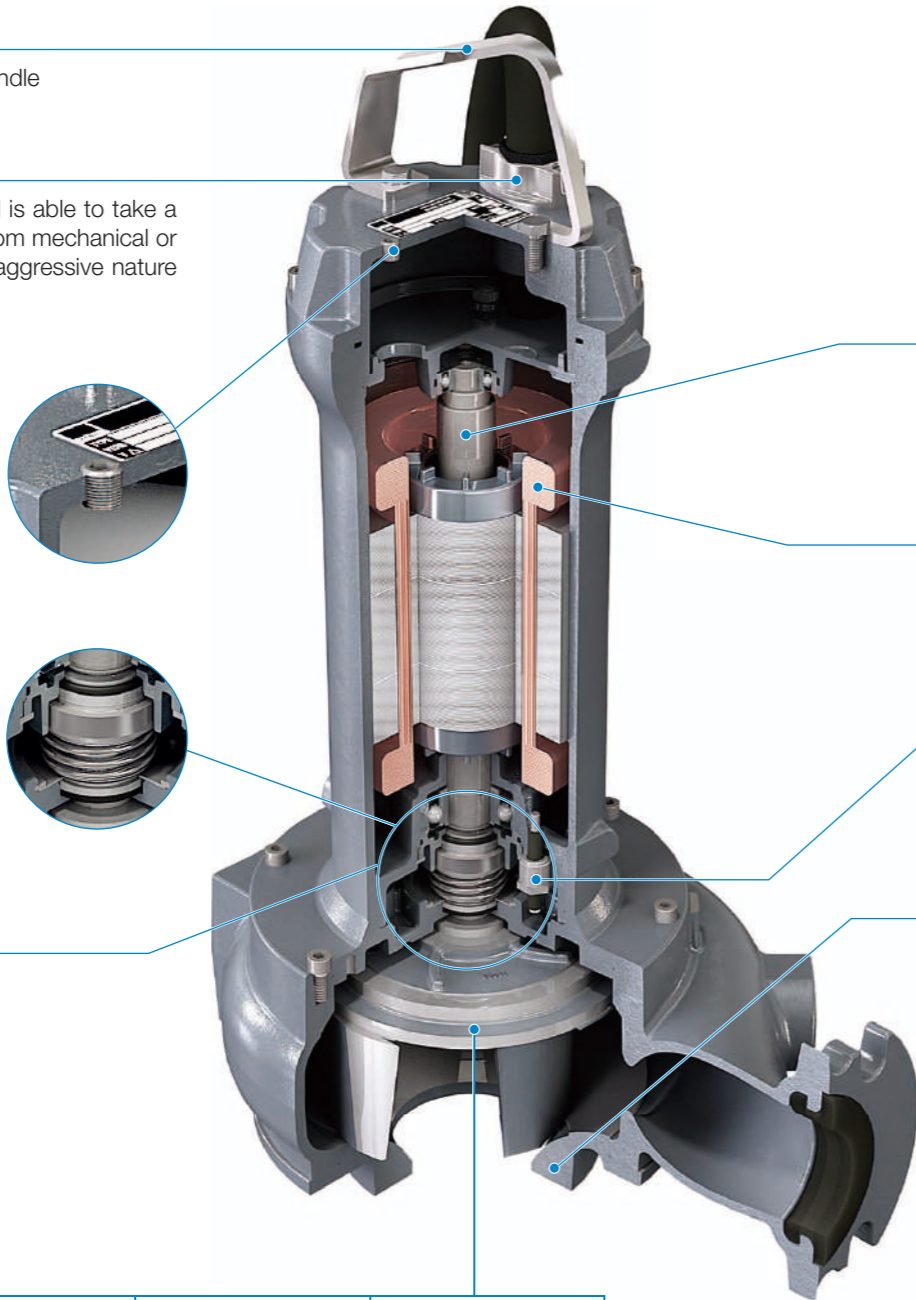

Special points

MOTOR

Tsurumi MY-series is fitted with IP68 rated, high performance induction motor, specially designed for submersible pumps. They come with superior Class H insulation rated at 180°C, to prevent motor burn out and enabling the pump to handle 20 evenly distributed starts per hour.

The motor frame and assembly to the pump parts are specifically designed to improve heat exchange and subsequent cooling by means of the surrounding water. Capable of handling variable speed, all Tsurumi MY-series high efficiency motors are capable of utilizing the full available power.

SHAFT

Tsurumi MY-series uses SUS431 grade stainless steel for shaft material with superior strength, hardness and corrosion resistance properties than the usual SUS420 stainless steel.

For convenience during maintenance, the shaft has been tapered for easy assembly of the impeller.

SENSORS

Tsurumi MY-series pumps come with thermal sensors embedded on the stator windings which prevents the over-heating of the motor. Should the winding temperature of the motor rise to the actuating temperature of the sensor, it will cause the control panel to shut the power supply to the pump.

Electrode type leakage sensor is installed inside a large oil chamber to detect water incursion through the mechanical seal as a redundancy to prevent leakage into the motor chamber. (All 4-poles pump, and 2-poles pump above 2.2kW)

ANTI-CLOGGING SYSTEM [MYB] [MYG]

The special conformation of the hydraulic part ensures the expulsion of solids and prevents fouling of the impeller.

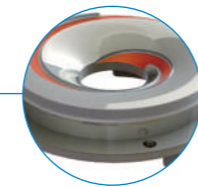

The special shape of a debossed groove in the hydraulic part ensures the non-clogging feature of the Tsurumi MY-series. Any solid or fibrous material that might get entangled and clogged in the impeller will be guided on to this groove and expelled through the grooved path. Due to the prevention of partial and soft clogging in the hydraulic parts, the performance is maintained throughout the operation cycle, without any compromise in flow and head.

PAINT

Bi-component epoxy paint (200 µm) is used as standard for all Tsurumi MY-series pumps. This has better resistance to corrosion and is thicker than other Tsurumi series pumps.

MATERIAL

All the cast Iron parts used in Tsurumi MY-series pumps is in FC 250 grade, which is stronger and harder than cast iron parts of other pumps.

Mechanical Seal with two pairs of Silicon Carbide seal faces is enclosed in the oil chamber to prevent leakage into the oil chamber and subsequently to the motor chamber. Due to the hardness of Silicon Carbide, the abrasion of sealing faces is less significant, ensuring the sealing feature for long time.

MYB (Open Channel)

Hydraulics

- Open Channel impeller
- Large free passage

Suitable for

- Recirculation of industrial and process waters
- Civil lifting
- Drainage and lifting of water from first rainfall tanks

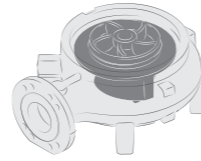

Range characteristics

Type of impeller	Open Channel
Power (P2)	0.37 - 18.5 kW
Poles	2 / 4 / 6
Discharge	V GAS 1 1/4" - 2"
	H DN 65 - 250
Free passage	max 110 mm
Max flow rate	205 l/s
Max head	50 m

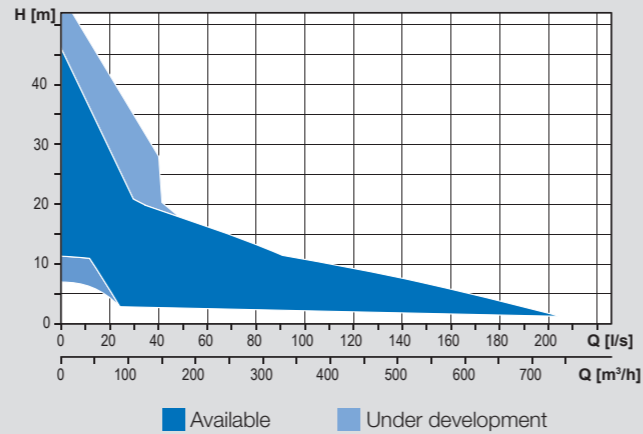

MYG (Grinder)

Hydraulics

- Multi-channel open impeller
- Grinding system with rotary knife

Suitable for

- Lifting of liquids containing fibres and filaments
- Professional and industrial applications
- Livestock farms

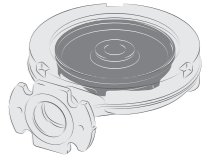

Range characteristics

Type of impeller	Grinder
Power (P2)	0.75 - 9 kW
Poles	2
Discharge	V -
	H GAS 1 1/2" - 2" DN 40 - 100
Free passage	-
Max flow rate	8.4 l/s
Max head	53.5 m

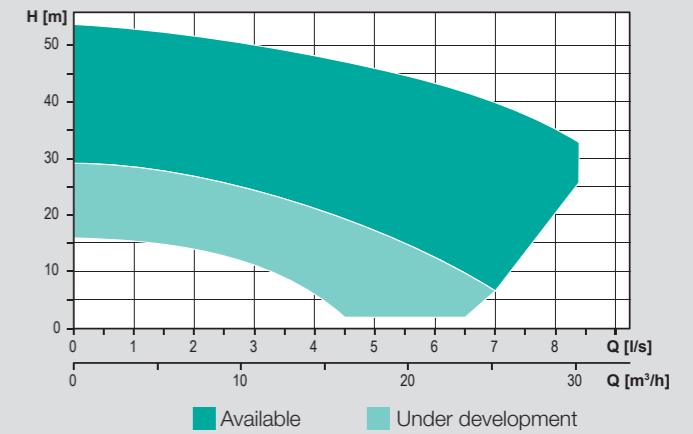

MYU (Vortex)

Hydraulics

- Vortex impeller
- Full free passage

Suitable for

- Biological liquids and wastewater
- Civil and industrial lifting
- Wastewater treatment plants and livestock farms

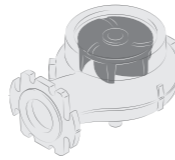

Range characteristics

Type of impeller	Vortex
Power (P2)	0.37 - 15 kW
Poles	2 / 4 / 6
Discharge	V GAS 1 1/2" - 2 1/2"
	H DN 65 - 150
Free passage	max 125 mm
Max flow rate	106 l/s
Max head	24.5 m

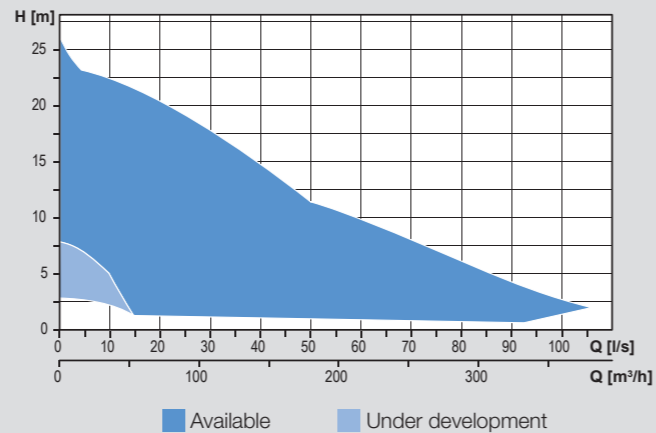

MYS (High Head)

Hydraulics

- Multi-channel open impeller
- High manometric head

Suitable for

- Industrial applications and car-washes
- Clean water in fountains and water features
- Irrigation and fish farming

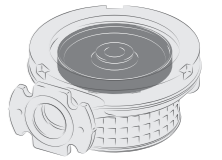

Range characteristics

Type of impeller	High Head
Power (P2)	0.75 - 9 kW
Poles	2
Discharge	V -
	H GAS 1 1/2" - 2" DN 40 - DN 50
Free passage	max 10 mm
Max flow rate	10.5 l/s
Max head	52 m

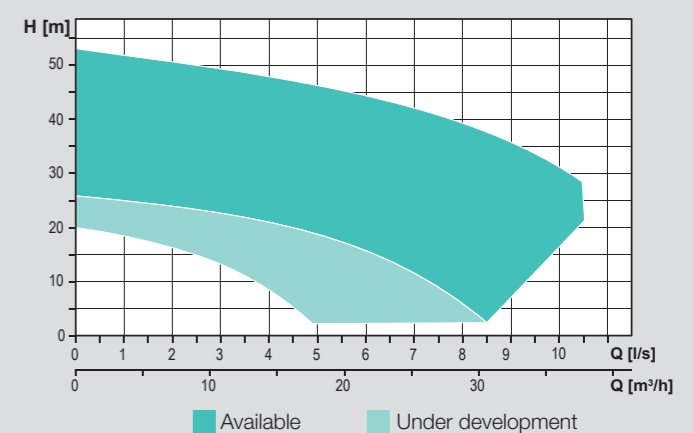



Code: 29040020920400000
Version: 01

Product images and specifications may differ from actual products due to improvements. The OO series and model OO are indicated with our series/model codes in this catalog.

**TSURUMI
MANUFACTURING CO., LTD.**

Your Dealer

© 2019 TSURUMI MANUFACTURING CO., LTD.
Printed in Japan IA150-A NZ-E-G-W