



Submersible Wastewater Pumps
Channel Impeller

NH



NH series is a cast iron made, submersible wastewater pump utilizing 2-pole motor. This impeller is a shrouded two-channel impeller. Each channel is designed to have a larger area and it enables the pump to be suitable for pumping wastewater containing a certain size of solids. The pumps are available in six motor sizes ranging from 1.5 to 7.5kW and available in either High-Head or High-Volume Type.

1 Anti-wicking Cable Entry

An anti-wicking block is provided at the cable entry section of the motor chamber. Even if the cable jacket becomes damaged or the tip of the cable is accidentally immersed in water, this device prevents water from traveling into the motor chamber through capillary action.

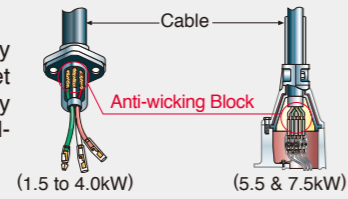

2 Motor Protector

A built-in thermal motor protection device reacts to the excessive heat caused by overcurrent or run-dry conditions. It not only cuts off the motor circuit automatically but also resets by itself. When the motor cools down to a safe operating temperature, the motor restarts.



3 Dual Inside Mechanical Seal

A mechanical seal with dual seal faces containing silicon carbide (SiC) is equipped with the oil chamber. As both upper and lower sealing faces are lubricated by the oil only, it ensures a longer life of the product and a stable sealing effect.

4 Oil Lifter (Patented)

The Oil Lifter is a lubricating device that forcibly lubricates the mechanical seal. It further stabilizes the functions of the mechanical seal and extends the life expectancy of the seal and also the maintenance term.

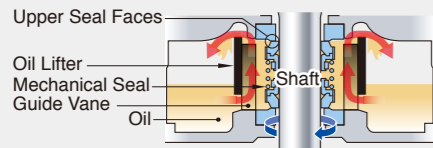

5 Air Release Valve

In order to prevent "air lock", an air release valve is built in the pump casing. The valve is similar to a ball check valve. When air goes through the valve, the ball stays at the bottom, but when the pumped water starts to flow, it closes the outlet by its buoyancy.

6 Seal Pressure Relief Port (5.5 & 7.5kW only)

A small chamber is provided between the oil seal and the shaft hole of the pump casing, and this chamber is led to the outside by this hole. With this device, the pumping pressure does not act on the mechanical seal. The mechanical seal is protected from over rated limit.

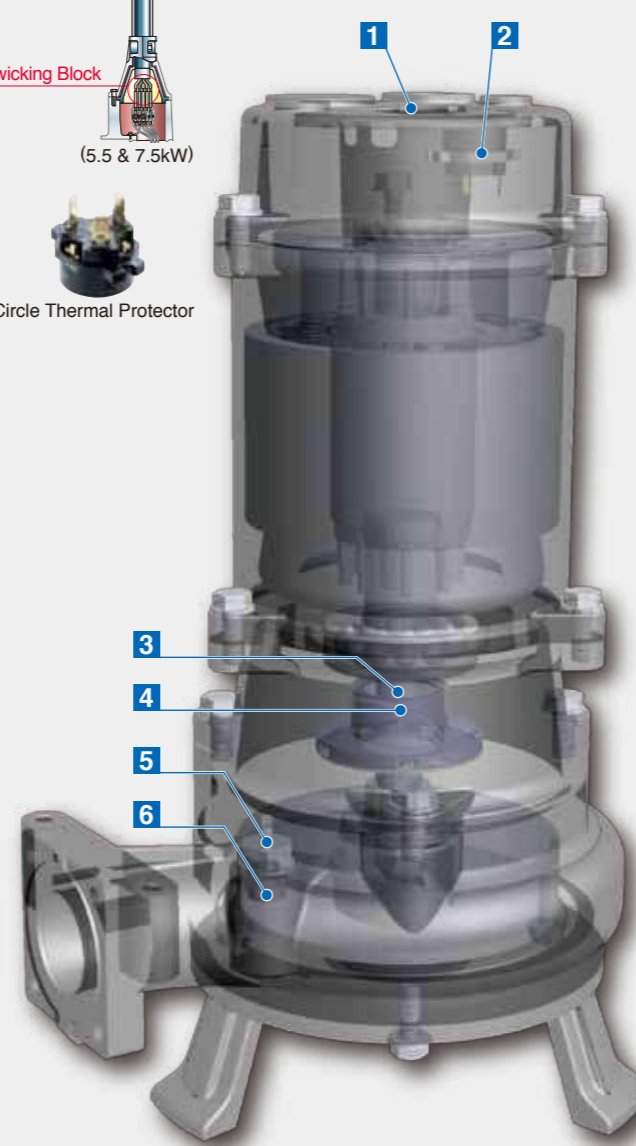

Guide Rail Fitting System

The guide rail fitting system connects the pump to and from the piping easily just by lowering and hoisting the pump, allowing easy maintenance and inspection without the need to enter the sump.

The TOS is the standard guide rail fitting system made of cast iron and is compatible with cast iron pumps.

Accessories

- Duckfoot Bend
- Guide Support
- Guide Hook
- Lifting Chain 5m (with Shackles)
- JIS 10kg/cm² Flange

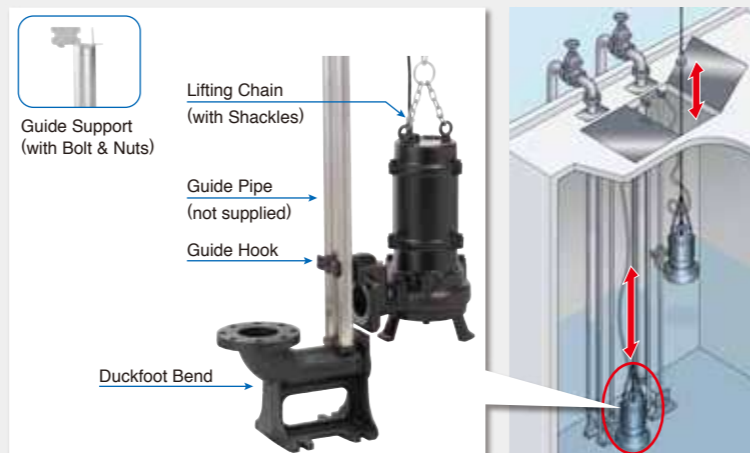

Performance Curves

It is not recommended to operate the unit continuously along the dashed curve.

<High-Head Type>

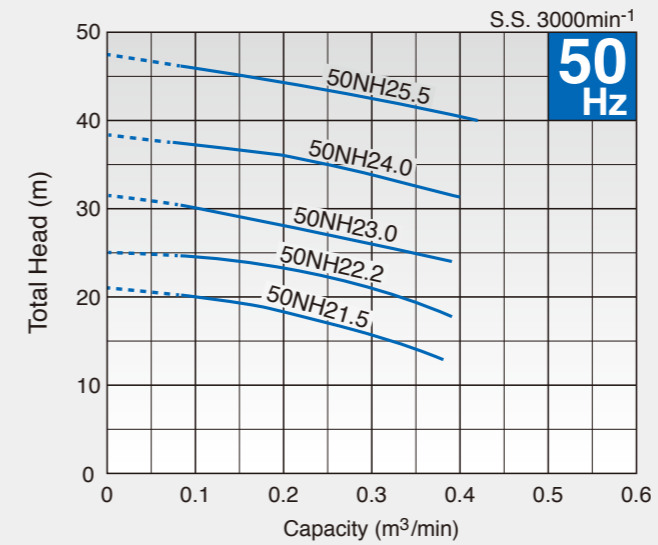

<High-Volume Type>

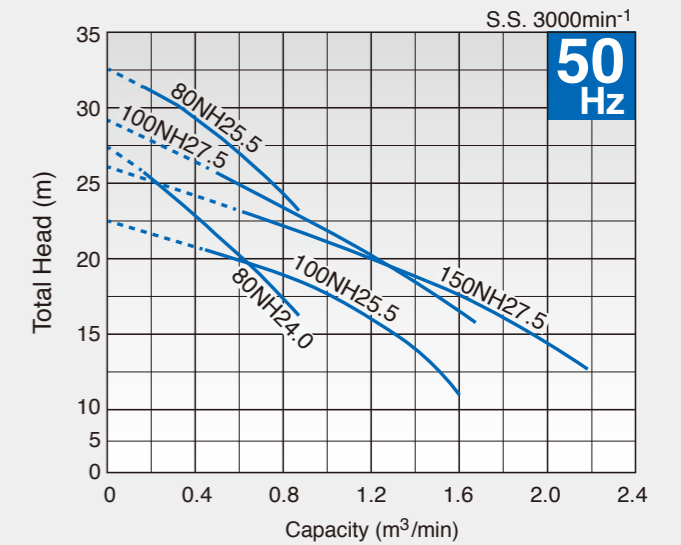

Model Selection 50Hz

Discharge Bore mm	Model		Motor Output kW	Phase	Starting Method	Solids Passage mm	Dimensions L x H mm		Dry Weight kg		Cable Length m
	Free Standing	Guide Rail Fitting					Free Standing	Guide Rail Fitting	Free Standing	Guide Rail Fitting	
50	50NH21.5	TOS50NH21.5	1.5	Three	D. O. L.	15	446 x 475	628 x 534	39	35	6
50	50NH22.2	TOS50NH22.2	2.2	Three	D. O. L.	17.5	454 x 510	637 x 569	44	39	6
50	50NH23.0	TOS50NH23.0	3.0	Three	D. O. L.	25.5	455 x 540	637 x 597	50	46	6
50	50NH24.0	TOS50NH24.0	4.0	Three	D. O. L.	25.5	496 x 557	679 x 611	56	51	6
50	50NH25.5	TOS50NH25.5	5.5	Three	D. O. L.	19.5	497 x 790	679 x 844	90	86	6
80	80NH24.0	TOS80NH24.0	4.0	Three	D. O. L.	26	522 x 563	696 x 632	61	54	6
80	80NH25.5	TOS80NH25.5	5.5	Three	D. O. L.	17.5	515 x 793	688 x 860	96	89	6
100	100NH25.5	TOS100NH25.5	5.5	Three	D. O. L.	35.5	569 x 835	788 x 913	105	95	6
100	100NH27.5	TOS100NH27.5	7.5	Three	D. O. L.	32.5	597 x 835	816 x 908	114	104	6
150	150NH27.5	TOS150NH27.5	7.5	Three	D. O. L.	31	720 x 850	915 x 976	140	117	6

• All weights excluding cable
Weights of guide rail fitting excluding duckfoot bend

Applications

- Draining wastewater from kitchen at a hotel, restaurant, and hospital, etc.
- Drainage from factory, underground car park, and basement, etc.
- High-head pumping of wastewater containing solid matters

Dimensions

Free Standing

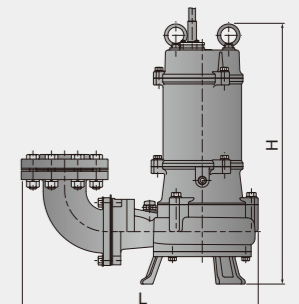

Guide Rail Fitting

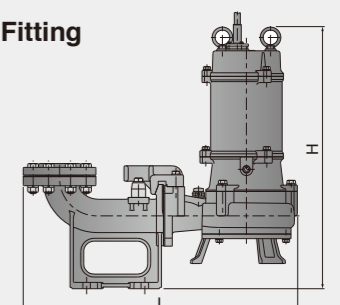

Model Number Designation

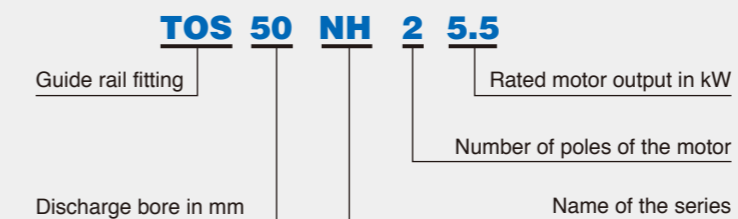



We reserve the right to change the specifications and designs for improvement without prior notice.

**TSURUMI
MANUFACTURING CO., LTD.**

Your Dealer